

# Operation Manual



BIBD 201 to 205

## BOD Incubator

# Index

---

Notification.....	1
Safety Instructions.....	3
Safety Precaution.....	4
Product (Application, operating principle, Parameters).....	5
Structure.....	6
Device Installation.....	9
Operation Method.....	11
Alarm and Security Functions.....	13
Daily use, Maintenance and Care.....	14
Troubleshooting.....	15
Specification Configuration Table .....	15
Product Packing List.....	16

# 01 Safety Instructions

## Notification

- To ensure the safe use of this equipment, please read this manual carefully before use.
- Keep this manual in a place convenient for users of this equipment to consult.
- The company does not undertake the safety guarantee for the use and operation methods other than those specified in this manual.
- This instruction manual is only for the use of equipment users and maintenance personnel, please keep it properly.
- The equipment is subject to change due to the improvement of product function and performance without further notice.
- The manual shall not be copied in any form without the written permission of the company.

## Safety Instructions

This manual contains important information about safe use, which must be followed by the operator.

keep this manual in a place convenient for users of this equipment.

The signs described in this section will appear on the equipment and in this manual, so that you can safely and correctly operate the equipment and protect the user or any other person from possible injury.

- Warning  
 Warning

Observe the items under the warning sign, otherwise it may cause danger to personnel and cause serious injury or death.

- Caution  
 Observe the items under the caution sign, otherwise it may cause personal injury or equipment damage and related property loss.

- Identification meaning

 Prohibition

-  Follow strictly
- Marks on device

 AC

 Protective conductor terminal

| Power on

 Power off

 Warning, Caution, Danger

## 02 Safety Precaution



### Warning

- ⊘ This equipment shall not be placed outdoors for use.
- ❗ This equipment can only be installed by qualified engineering technicians or maintenance personnel.
- ❗ The equipment shall be installed on a solid ground and proper care shall be taken to prevent the equipment from overturning.
- ⊘ Do not install this equipment in damp places or places where it may be splashed with water.
- ⊘ Do not install this equipment in a place where flammable or volatile materials are stored.
- ⊘ Do not install this equipment in the place with acid or corrosive gas.
- ⚡ Please use a power socket with a grounding wire to prevent electric shock.
- ⊘ The equipment shall not be grounded through gas, water supply pipe, telephone line or lightning rod.
- ❗ Please use the special power supply indicated on the nameplate of the equipment.
- ⊘ If the container cannot be sealed, do not store volatile or flammable substances in this equipment.
- ⊘ Do not insert metal objects such as nails or wires into any holes and gaps or any outlets of this equipment.
- ❗ When storing toxic, harmful or radioactive substances, please use this equipment in a safe area.
- ❗ Before repairing or maintaining the equipment, be sure to turn off the power switch (if any) and disconnect the power supply of the equipment.



### Warning

- ⊘ Do not touch any electrical parts such as power plugs or any switches with wet hands.
- ❗ Ensure that you do not inhale drugs or aerosols around the equipment during maintenance.
- ⊘ Do not directly splash water on the equipment.
- ⊘ Do not place containers containing water on the equipment.
- ⊘ Do not drag, wind or bind the power cord, or damage the power plug.
- ⊘ Do not use the loose power cord of the plug.
- ⊘ Users shall not dismantle, repair or refit the equipment without the authorization of our factory or the guidance of authorized personnel.
- ❗ If the device is not working properly, please unplug the power plug.
- ❗ When unplugging the plug from the power socket, firmly hold the power plug instead of pulling the wire of the power plug.

- ❗ Before moving the equipment, unplug the power plug.
- ❗ When the equipment is not used for a long time, unplug the power plug.
- ❗ If the equipment is left idle for a long time in an unsupervised area, make sure that children do not approach the equipment and that the door cannot be completely closed.
- ❗ The equipment shall be scrapped by corresponding personnel.

⊘ Do not put the plastic bag within the reach of children.



Caution

- ❗ After the dust on the power plug is cleaned, firmly insert the plug into the socket.
- ❗ In case of power failure or power cut off, check the temperature, segment number, timing and other settings after restarting the equipment.
- ❗ When the equipment is not used for a long time after purchase, it shall be stored in a ventilated and dry environment.
- ❗ Proper handling tools or qualified personnel shall be prepared when handling equipment.
- ❗ It shall be ensured that there is a transport channel with sufficient width and height. If it is necessary to transport to the second floor or above, it shall be ensured that the elevator can accommodate the size of the equipment enough to ensure the safety of the equipment.
- ⊘ If the container cannot be sealed, do not store acid, alkali and other corrosive substances in the equipment.

## 03 Product(Application, operating principle,Parameters)

### Application

BOD Incubator BIBD 200 series is a high precision constant temperature incubator with heating and cooling control. It is applicable for the plant cultivating, testing of seed breeding, cultivating and storing the bacteria, mold, microorganism, analyzing water and BOD measure. It is applicable in bio-genetic engineering, medical college, sanitation epidemic prevention, medicine testing, farming and fisheries institutes for research.

### Principle of Operation

Biochemical incubator transforms the actual temperature felt by temperature sensor in chamber to electrical signal and control the work of heater and compressor by microcomputer to reach the required temperature.

### Technical Parameter

Model	BIBD-201	BIBD-202	BIBD-203	BIBD-204	BIBD-205
-------	----------	----------	----------	----------	----------

Temp. Range	4°C~70°C			
Temp. Uniformity	±1°C (@37°C)			
Temp. Fluctuation	±0.5°C			
Power Supply	~220V ±10V, 50/60Hz			
Power Consumption	1000W	1100W	1350W	2000W
Refrigerant	R134			
Work Ambient	Ambient temp.:10~30°C; Relative humidity≤70%RH			
Equipment Class	Class I			

Note: This machine has the function of low temperature automatic frost. It is normal that the temperature will fluctuate during low temperature automatic frost!

## 04 Structure

### Component

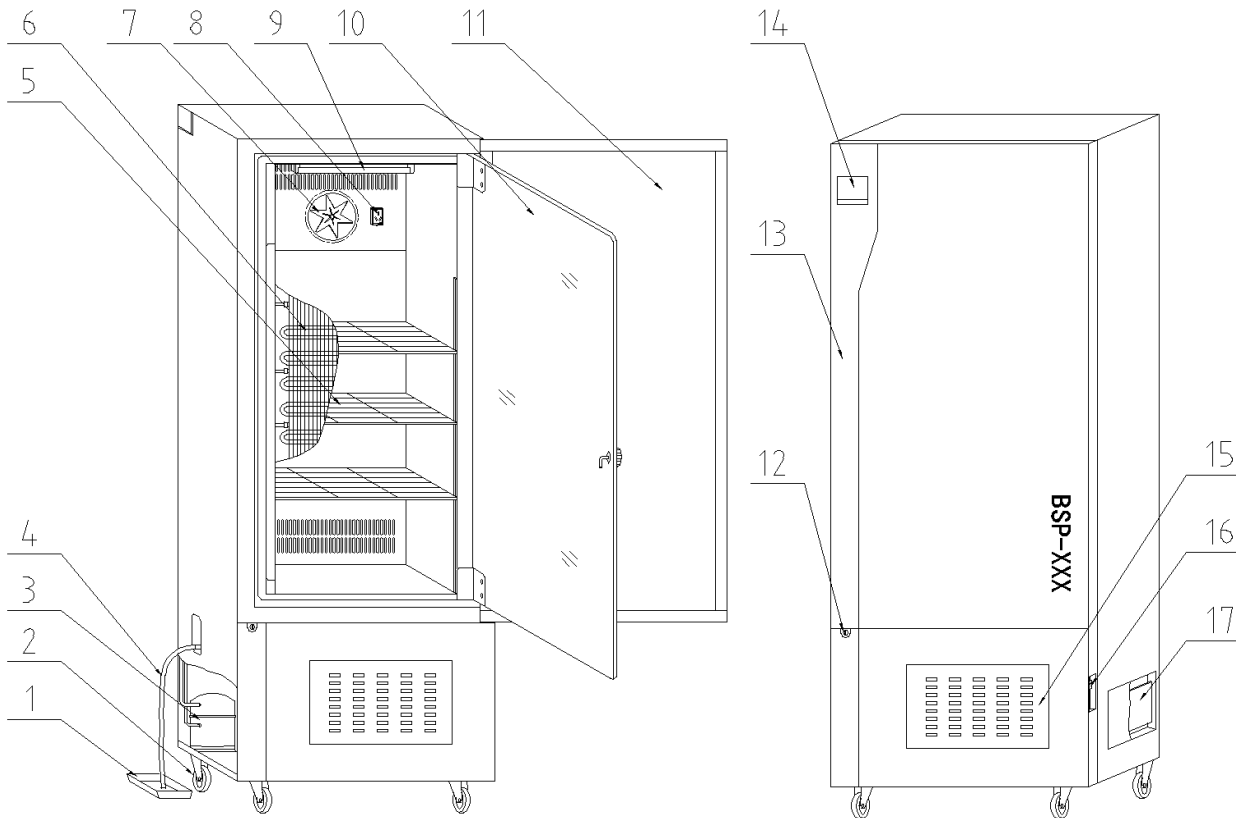

Schematic diagram of single door product structure (for reference only)

- |                    |                    |                                    |                  |
|--------------------|--------------------|------------------------------------|------------------|
| 1. water collector | 2. truckle         | 3. compressor                      | 4. overflow pipe |
| 5. shelves         | 6. evaporator      | 7. fan                             | 8. socket        |
| 9. lamp            | 10. glass door     | 11. outer door                     | 12. door lock    |
| 13. trim panel     | 14. display screen | 15. condensate fan cleaning window |                  |
| 16. power switch   | 17. control panel  |                                    |                  |

Structure

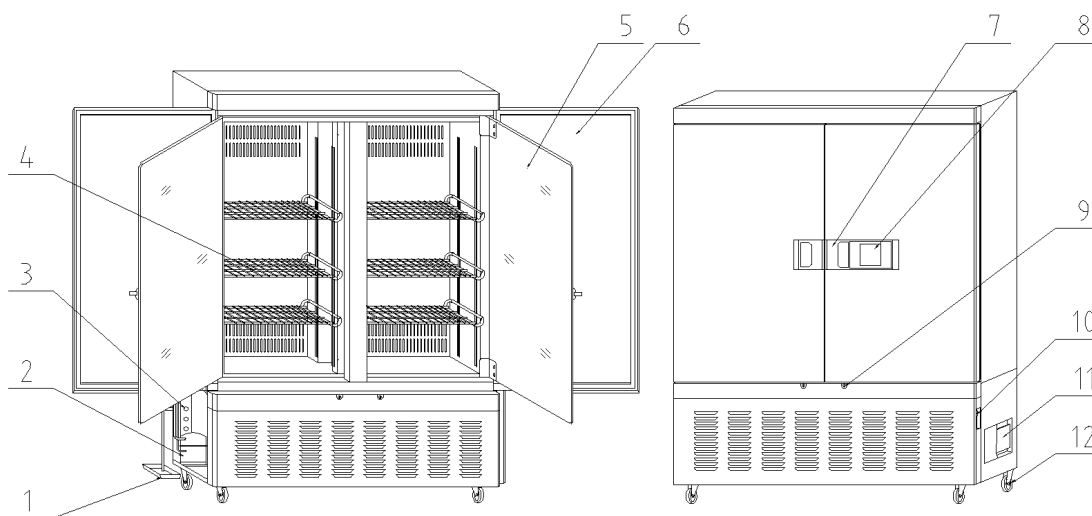

Schematic diagram of double door product structure (for reference only)

- |                    |                  |                      |                   |
|--------------------|------------------|----------------------|-------------------|
| 1. water collector | 2. compressor    | 3. overflow pipe     | 4. shelves        |
| 5. glass door      | 6. outer door    | 7. outer door handle | 8. display screen |
| 9. door lock       | 10. power switch | 11. control panel    | 12. truckle       |

## Structure

## Control panel

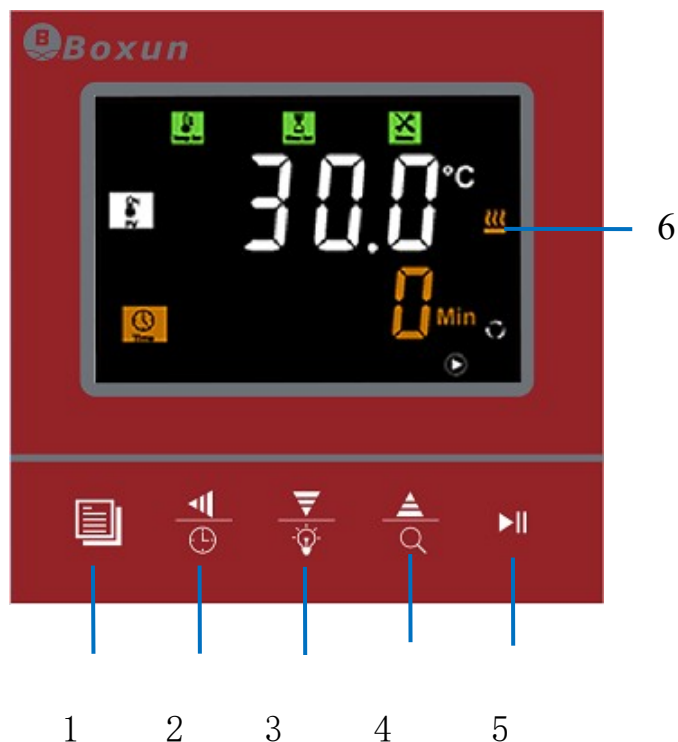

### Key definition:

1 Set key: click into the set state, press the key for 3S to enter the internal parameter state;  
 2 Shift / Reservation key: in the setting state, click it to move the input cursor; in the standby state, click it and "ord" appears, then set the reservation time (0.5h increment); click it again to enter the reservation countdown state, it displays "oln" and the reservation starts; in the reservation countdown state, long press the reservation key to cancel the reservation, or click the run key to exit the reservation and run directly ;

3 Decrease / Illumination key: in the setting state, click or long press this key to reduce the setting value; in the main interface, click it to turn on or off the lighting (UV) lamp;

4 Increase / Query key: in the setting state, click or long press this key to increase the setting value; in the main interface, click it to query the current set temperature ("CP -") and set time ("CT -");

Constant value mode:

Set temperature ("CP -") and set time ("CT -").

Multi value mode:

Set temperature and set time.

("CP1": the current temperature is the set temperature of the first segment, "CP15": the current temperature is the set temperature of the 15th segment)

("CT1": the current time is the set time of the first segment, "CT15": the current time is the set time of the 15th segment);

5 Stop / Run key: click to start running or long press to stop running;

6 State and indication area: display alarm, heating, refrigeration and other state information.



## 05 Device Installation

### Installation Site

Please install the device at eligible places as followings for better use:



**Note: Temp: 10~30°C; Humidity: below 70%RH.**

■ Out of direct sunlight.

Do not install the equipment in a place with direct sunlight. Installation in a location exposed to direct sunlight may cause the equipment to fail to achieve the expected performance.

■ With adequate ventilation.

If the equipment is used in a narrow and airtight room, it may not be able to dissipate heat in time, causing the equipment to fail to work normally. The distance between the equipment and the wall must be more than 10CM.

■ Away from heat sources.

Avoid installing equipment near heat sources such as boilers or heaters. Excess heat from the outside will affect the expected performance of the equipment.

■ With solid and flat ground.

The equipment must be installed on a solid and flat ground. Uneven ground or inclined installation of equipment may cause equipment failure or personal injury. The shaking and noise of the equipment can be avoided by installing the equipment under stable conditions.

■ High humidity is unlikely to occur.

The equipment shall be installed at a place where the humidity is not more than 70%. If it is installed in a place with high humidity, it may cause electric leakage or electric shock.



### Warning

Do not use this equipment outdoors. If the equipment is splashed by rain, it may cause electric leakage or electric shock.

Do not place the equipment in a damp place or a place where it may be splashed with water, or it may cause electric leakage or electric shock due to the reduction of insulation.

- No flammable or corrosive gas.

Do not install the equipment in a place with flammable or volatile substances, otherwise it may cause explosion or fire. And it may cause electric leakage, electric shock or equipment damage due to corrosion.

### Installation

#### 1. Remove the packaging materials

After removing all packing materials, open the door and ventilate the equipment. If the shell and panel are dirty, please remove the dirt with neutral detergent and clean the residual neutral detergent with clean water. After cleaning, wipe it with a wet cloth, and then wipe it with a dry cloth.

#### 2. Fix the equipment

The device can be fixed with two brake wheels at the front of the equipment after being placed in place to prevent the equipment from moving.

#### 3. Grounding



#### Warning

Please use a power socket with a grounding wire to prevent electric shock. If the power socket is not grounded, the grounding wire must be installed by qualified engineers or technicians.

Do not ground the equipment through gas pipe, water supply pipe, telephone line or lightning rod. Such grounding may cause electric shock due to incomplete circuit.

#### 4. If idle equipment

Before closing the door and idling the device, make sure the device is completely dry.

#### 5. Before moving the equipment

Before moving the equipment, if there is a water collector, the water collector should be emptied. Spilled or splashed water may cause electric leakage or electric shock.

### Preparation Before Operation

Before starting the equipment for the first time, please follow the following procedures:

1. Take out the shelves and other accessories inside the equipment.
2. Wipe the inner wall of the device with gauze soaked in alcohol for disinfection, and then wipe the alcohol with dry gauze.
3. Put the shelves into the equipment according to your own experimental requirements.
4. Before use, the overflow pipe shall be inserted into the overflow port on the left side of the equipment (refer to the schematic diagram of product structure), and a water collector shall be placed under the overflow pipe outlet for use.



#### Note:

Do not use sodium chloride solvent or other halide solution to clean the equipment, because it may cause rust.

## 06 Operation Method

### 1. Setting state

#### Mode selection

Symbol	Parameter name	Functional description	Range (Initial value)
Lc-	Password		121
H-	Mode selection	0: Constant value mode 1: Multi value mode	(0,1) 0

In the non-lock screen state, long press the setting key to enter the "Lc -" password input interface to enter the password. (The subsequent password input method is the same as this.)

Constant value mode (continuous operation when the time is set to 0)

Symbol	Parameter name	Functional description	Range (Initial value)
SP-	setting temperature	Set temperature during operation	30.0°C
ST-	setting time	The unit h/min is determined by the parameters in the password	(0~9999) 60

When the constant value mode is selected, click the setting key to set the temperature and time in turn.

Multi value mode (continuous operation when the number of segments is 1, the cycle is 1, and the setting time is 0)

Symbol	Parameter name	Functional description	Range (Initial value)
SC-	setting cycle	continuous operation when cycle is 0	(0~99)
SE-	setting segments	set the total number of segments	(1~30) 1
SPx	running temperature	running temperature of segment x	30.0°C
STx	running time	running time of segment x	(0~9999) 60

When multi value mode is selected, click the setting key to set the cycle, number of segments, temperature and time of each segment in turn.

### 2. View temperature and other parameters

Symbol	Parameter name
Lc-	password 47
CT-	chamber temperature
ET-	evaporator temperature

Hd-	ambient temperature
LS-	compressor speed

### 3. Lock screen

#### Lock key parameters

Symbol	Parameter name	Functional description	Range (Initial value)
Lc-	password		40
LoT	screen lock time	On the main interface, if no key is pressed during the screen locking time, the screen will be locked.	(0,9999) 3min
LoP	unlock password		(0,9999) 32

Unlock: click the setting key to display "Lok", and enter the unlock password to unlock.

### 4. Internal parameter status

#### Alarm parameters

Symbol	Parameter name	Functional description	Range (Initial value)
Lc-	password		11
AL-	overtemperature alarm	measuring temperature > set temperature + overtemperature protection temperature, prompt overtemperature alarm and disconnect heating	(0,50.0) 5.0°C
dL-	low temperature alarm	measuring temperature < setting temperature - low temperature protection temperature, prompt low temperature alarm	(0,50.0) 5.0°C
ALT	temperature alarm delay	time delay of overtemperature or low temperature alarm	(0,999) 0min
PLT	door opening alarm delay	alarm after opening the door for this time	(0,999) 0min

#### Measurement calibration

Symbol	Parameter name	Functional description	Range (Initial value)
Lc-	password		12
Pb-	chamber temperature zero adjustment	temperature zero adjustment=actual temperature value - instrument measured value	(-10.0,10.0) 0°C
Pk-	chamber temperature full adjustment	temperature full adjustment=1000 * (actual temperature value - instrument measured value) / instrument measured value	(-99,999) 0
EPb	evaporator temperature zero	temperature zero adjustment=actual temperature value - instrument measured	(-20.0,20.0) 0°C

	adjustment	value	
EPk	evaporator temperature full adjustment	temperature full adjustment=1000 * (actual temperature value - instrument measured value) / instrument measured value	(-99,999) 0

## System parameters

Symbol	Parameter name	Functional description	Range (Initial value)
Lc-	password		23
bd-	restore factory settings	0: not restore; 1: restore	(0,1) 0
SA-	power down memory	0: no; 1: with	(0,1) 0
Adr-	communication address	485 communication address	(1,32) 1
Hn-	minutes / hour	0: minute timing; 1: hourly timing	(0,1) 0
Et-	timing mode	1: Start timing when running; 2: Start timing when the temperature reaches	(1,2) 1

## Refrigeration parameters

Symbol	Parameter name	Functional description	Range (Initial value)
Lc-	password		9
FS-	wind speed setting	Wind speed gear setting	(50~100) 100%

**Note: Other parameters are internal debugging parameters, please operate under the guidance of professionals!**

## 07 Alarm and Security Functions

## Fault code indication

Code	Description	Code	Description
E01	power board not communicating	E0b	ambient temperature fault
E02	chamber temperature overflow	E0d	internal real-time clock fault
E03	chamber overtemperature	E0E	parameter storage failed
E04	low temperature of chamber		
E21	evaporator temperature		

## 08 Daily use, Maintenance and Care

- ⊘ During the transportation of biochemical incubator, it is forbidden to place it upside down or horizontally at more than 45 degrees.
- ⊘ Do not change the set value frequently during use, so as to avoid overloading caused by frequent startup of the compressor, which will affect the service life of the equipment.
- ⚠ This machine is equipped with two sets of fuses. In case of failure during operation, please cut off the power supply first, check whether the fuses are in good condition, and then check other parts.
- ⚠ Be sure to close the inner door, and then close the outer door. If the inner door is not fully closed, even if the outer door is closed, the equipment may not work at its maximum performance. Please be careful when closing the door, and do not damage the door seal by exerting too much force.
- ⚠ In order to maintain the appearance of the equipment, do not wipe the surface with corrosive solution. Wipe the chamber with dry cloth or alcohol to keep the chamber clean.
- ⚠ When the equipment is not in use, keep the chamber dry and cut off the power supply.
- ⚠ To ensure uniform temperature in the chamber, check whether the axial flow fan in the chamber operates normally. During the experiment, the articles in the chamber should not be placed too tightly and should not block the air outlet of the fan to facilitate the air circulation in the chamber.
- ⚠ Do not touch or collide the temperature sensor in the chamber to avoid the temperature to be out of control.
- ⚠ Be sure to fix the shelves properly, otherwise the culture objects may be damaged.
- ⊘ Do not lean against or put pressure on the glass, which may cause injury to personnel.
- ⊘ Personnel shall not lean against the equipment door to prevent personal injury and equipment damage caused by equipment overturning or door damage.
- ⚠ In case of equipment failure, please ask professional personnel for maintenance or contact the factory. Users are not allowed to dismantle and repair the equipment at will.



## 09 Troubleshooting

Fault	Check / solution
Sensor fault alarm	·The temperature sensor is abnormal, check the temperature sensor, model PT100.
The temperature does not rise to the set value	·Check the electric heating pipe.
No display on the screen	·Check the device fuse (15A). ·Check whether the power switch indicator is on. If the indicator is not on, replace the power switch. ·Check whether the incoming plug wire has ~220V

## 10 Specification Configuration Table

Name	BIBD 200 series		
Model	BIBD-201	BIBD-202	BIBD-203
Housing Dimensions	630×680×1250	650×680×1400	650×740×1726
Internal Dimensions	490×390×610	510×390×760	510×450×1090
Volume	100L	150L	250L
Model	BIBD-204	BIBD-205	
Housing Dimensions	745×930×1695	1503×910×1820	
Internal Dimensions	600×640×1050	1220×585×1123	
Volume	400L	800L	
Shell	Made of cold-rolling steel with static spray plastic		
Inner vessel	Made of mirror stainless steel		
Door	double-door design		
Inner door	Made of 5mm thickness of toughened glass		



Shelf	Made of carbon steel with chromium plating and adjustable
Insulation system	Fill in Styrofoam
Refrigeration system	Non-CFC refrigerant which is efficient and energy-saving; Integrated refrigeration system;
Heating system	Adopt heating pipe
Fan	Axial flow fan
Temp. Sensor	PT100
Display	LCD screen
Alarm system	Upper limit temp. alarm; Temp. sensor fault alarm

 Note: The design and specifications are subject to change without notice.

## 11 Product Packing List

No.	Name	Qty	Remark
1	Instruction Manual	1 pc	
2	Certificate of Inspection	1 pc	
3	Quality Warranty Card	1 pc	
4	Shelves	2 pcs (100L) 3 pcs (150L) 4 pcs (250L) 4 pcs (400L) 6 pcs (800L)	
5	Water Collector	1 pc	
6	Overflow Pipe	1 pc	Plastic hard pipe





Email: [contact@biolabscientific.com](mailto:contact@biolabscientific.com)  
Website: [www.biolabscientific.com](http://www.biolabscientific.com)